

1 2 3 4 5 6

A

B

C

D

A

B

C

D

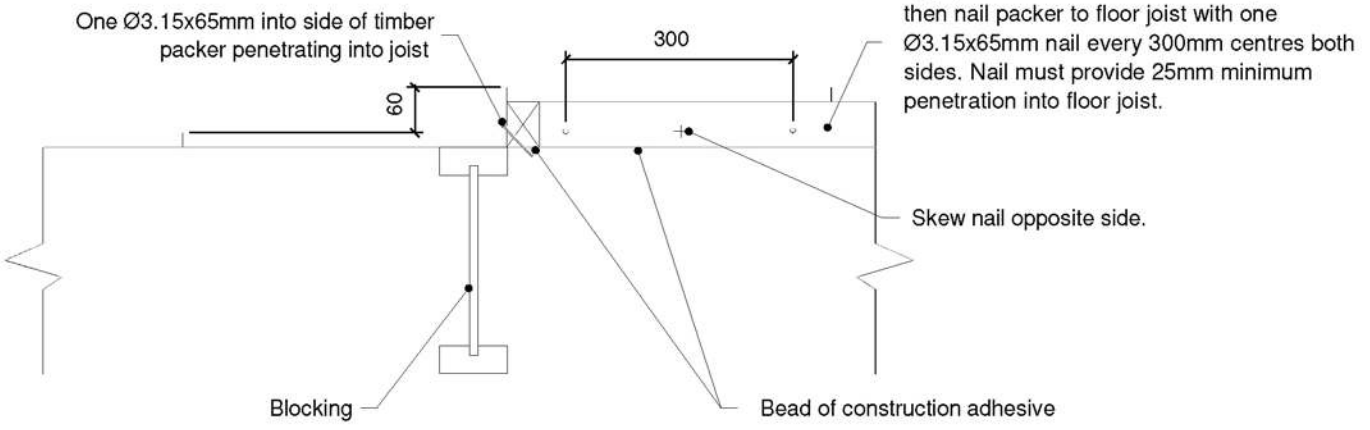
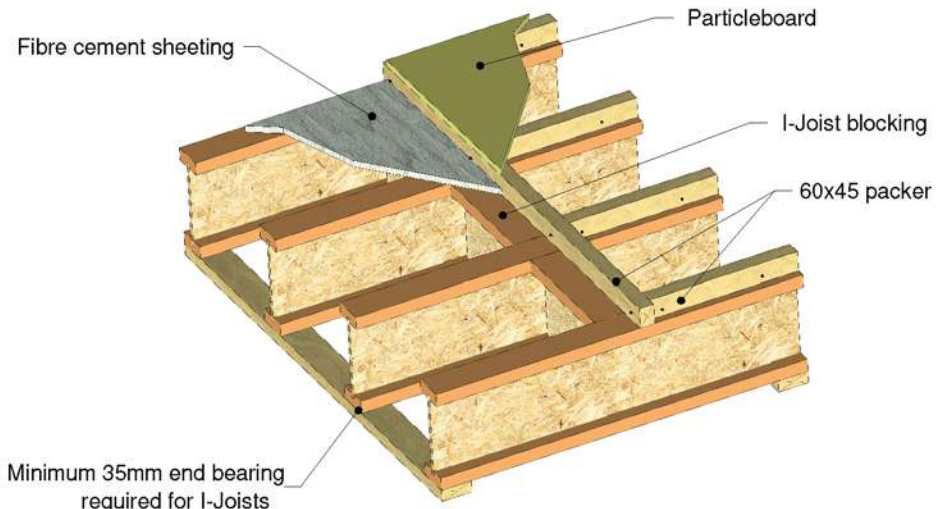

- Notes:
1. It is the installer's responsibility to ensure that any areas subject to moisture are correctly detailed as per NCC or local authority requirements.
 2. Dindas custom packing 60x45 to be used to pack joists to create the step down areas. **Packing is to be glued with min 5mm bead of construction adhesive and nailed at 300 alternate spacings**

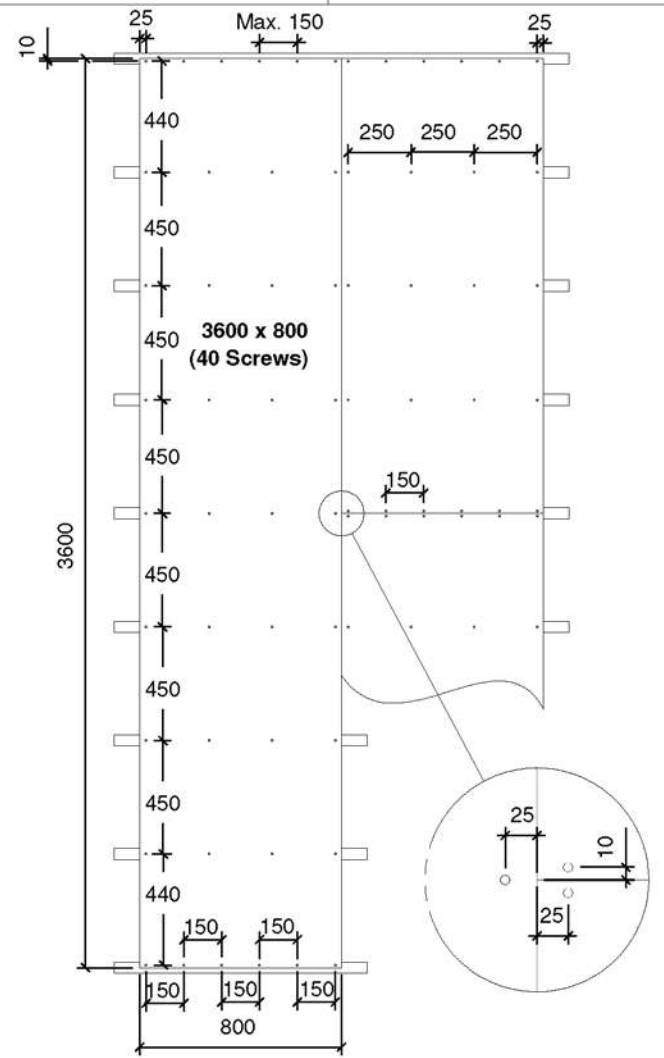

- 250mm maximum centres - body of sheet
- 150mm maximum centres - sheet edges
- 25mm from T&G edges
- 10mm (minimum from square edges (butt joint))

Floor sheet fixing plan

your partner for engineered timber solutions

DATE CREATED:	13/11/2020
DRAWN BY:	B.S
CHECKED BY:	--
DWG REV:	--

TITLE:
BATHROOM STEP DOWN / FLOOR SHEET FIXING PLAN

- NOTES:
1. Dimensions are in millimetres.
 2. Tolerance on all dimensions to be +/- 0.5mm unless noted otherwise.
 3. Written dimensions take precedence over scaled dimensions.

Private Confidential & Copyright
This drawing is the exclusive property of Dindas Australia. Copyright & all rights reserved. You hereby agree and undertake that you will not in anyway utilize, copy reproduce or take advantage of the drawing (or any part thereof) and disclose any information to other parties without the written consent of Dindas Australia.

SIZE
A4
SCALE
N.T.S

1 2 3 4 5 6