

1

2

3

4

5

6

A

B

C

D

A

B

C

D

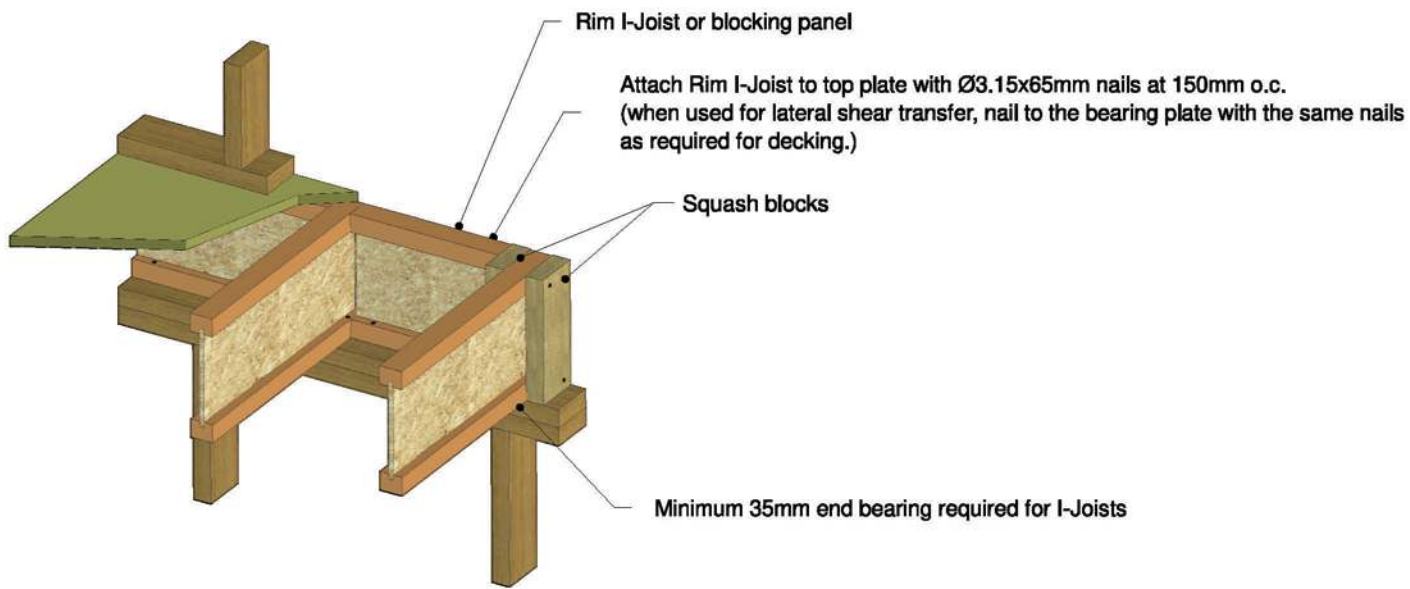

I-JOIST BOTTOM FLANGE FIXING

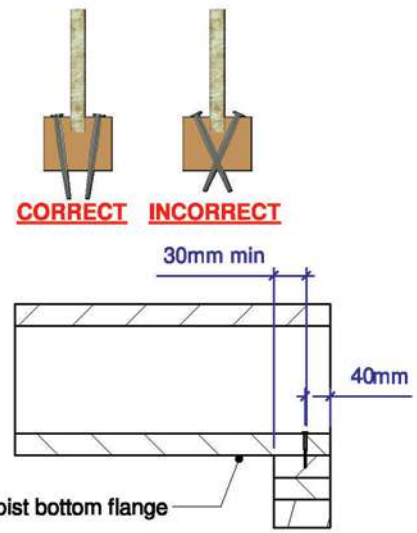

Attach I-Joist blocking to top plate with Ø3.15x65mm nails at 150mm o.c.
 To avoid splitting the flange, start nails at least 40mm from the end.
 Drive nails at an angle to prevent splitting of the bearing plate.(when used for shear transfer, nail to the bearing plate with the same nails as required for decking).

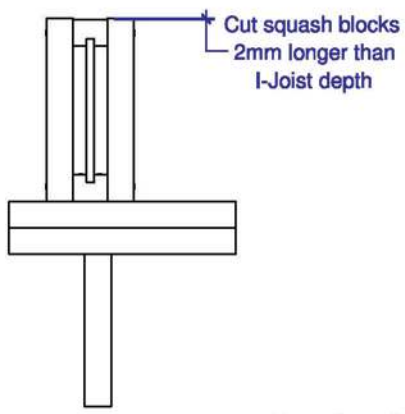

JOIST END VIEW

Note: Squash blocks are assumed to be in full bearing on the plate below.
 Fasten squash blocks to the top flange and to the top plate with one Ø3.15x65mm nail.

Squash Blocks	I-Joist	Squash Blocks Cross Section (mm x mm)	Max. Factored Vertical Load per Pair of Squash Blocks (kN)	
			MGP10 wall plate bearing analysis included	
			No	Yes
MGP10 (min.grade)	max. 400mm	35 x 90	64	30
		45 x 90	82	39
		45 x 140	127	61

your partner for engineered timber solutions

DATE CREATED: 28/07/2020
 DRAWN BY: B.S
 CHECKED BY: --
 DWG REV: --

TITLE:
**DETAIL 1D
 SQUASH BLOCKS**

NOTES:
 1. Dimensions are in millimetres.
 2. Tolerance on all dimensions to be +/- 0.5mm unless noted otherwise.
 3. Written dimensions take precedence over scaled dimensions.

Private Confidential & Copyright
 This drawing is the exclusive property of Dindas Australia. Copyright & all rights reserved. You hereby agree and undertake that you will not in anyway utilize, copy reproduce or take advantage of the drawing (or any part thereof) and disclose any information to other parties without the written consent of Dindas Australia.

SIZE
A4
 SCALE
N.T.S

1

2

3

4

5

6